

DURABILITY

A Guide for Residential Builders and Designers

BY DESIGN

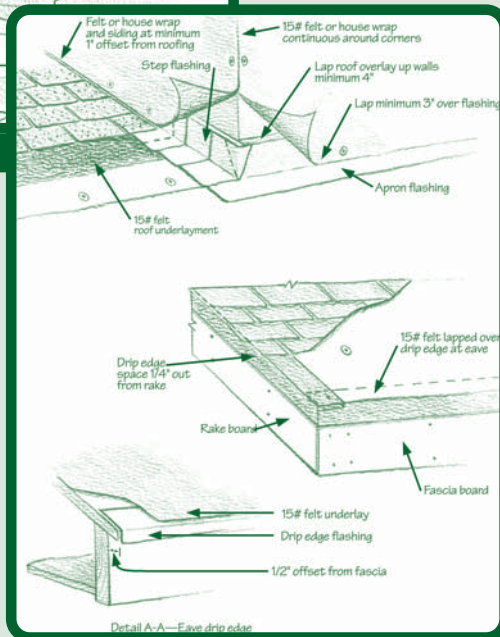
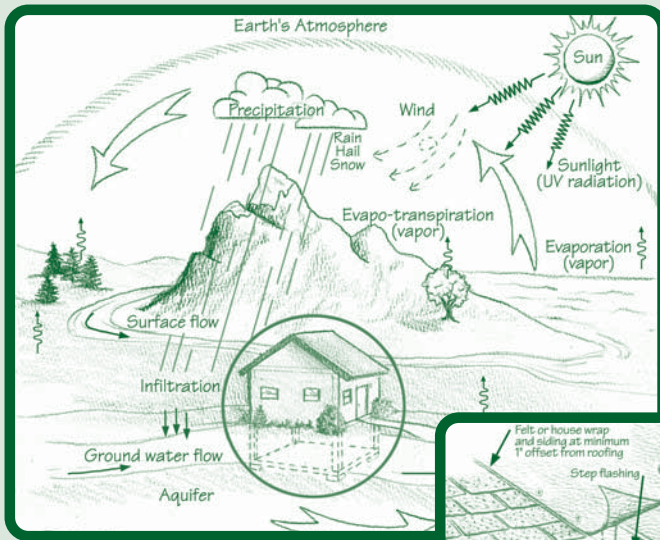

U.S. Department of Housing and Urban Development
Office of Policy Development and Research



CHAPTER 6 - Insects

6.1 General

Insects are not just nuisances, some are also a serious threat to building durability. The following types of insects are known to damage wooden materials in homes and in other structures:

- § Termites,
- § Carpenter Ants,
- § Wood-boring Beetles, and
- § Carpenter Bees.

While all of the above insects can pose a threat to wood-framed homes, termites are the most prevalent and damaging insect. Therefore, most of this chapter addresses issues and practices related to the control and prevention of termite infestation. Some of the practices for repelling termites, such as eliminating hidden areas that termites can travel through undetected, are also relevant to carpenter ants. Carpenter ants and wood-boring beetles, like termites, can be treated chemically with insecticides. Carpenter bees can be deterred by plugging entrance holes that commonly occur on wood siding and soffits.

There are about 56 species of termites in the United States that can be placed into two groups: subterranean (ground inhabiting) and non-subterranean (wood inhabiting). Subterranean termites are the most common and are responsible for most termite damage to wood structures. Therefore, this chapter focuses on subterranean termites. If non-subterranean termites are present, special measures may be necessary to eliminate them. Fortunately, non-subterranean termites live in much smaller colonies and are much slower acting than subterranean termites.

One variety of the subterranean termite group is the Formosan termiteñan Asian termite introduced to the United States following WWII. The Formosan termite is different from the native subterranean termite in that it has a much greater colony size and thus damages wood at a much faster rate. Estimates state that a colony of Formosan termites will consume nearly 1,000 pounds of wood per year, whereas other termite varieties will only eat a few pounds annually. Formosan termites are also more likely to survive in a building with minimal ground contact, even though they require a constant source of water like other subterranean termites. Formosan

termites are expanding in range, and are currently found in the Gulf Coast states and southern states along the Atlantic coast.

A termite hazard or probability map, shown in Figure 6.1, is frequently used by building code authorities, designers, and builders to determine when certain termite prevention or control methods should be used. Some building codes may vary in delineation of the termite probability zones based on local conditions. The termite hazard map generally corresponds to the geographic limits of reported termite damage as shown in Figure 6.2. The inclusion and degree of termite control and prevention used in a building depends on the risk of termite infestation as defined in Figures 6.1 and 6.2, as well as local experience.

In summary, termites like to eat wood and they don't care if it's in your home. In areas subject to termite infestation, at least one of the practices listed in Section 6.2 should be used.

6.2 Recommended Practices

There are basically three techniques for controlling or preventing termite damage:

- § Chemical soil treatment or baits,
- § Termite shields, and
- § Use of termite resistant building materials.

6.2.1 Recommendation #1: Chemical Treatment

Types

Chemical treatments for termite control come in a variety of forms. Generally, chemical treatments for termites include soil termiticides, termite baits, and treated wood products. This section will only discuss soil and bait termiticides.

Chemical soil treatments are designed to form a protective barrier around a structure to prevent termites from contacting or penetrating the building.

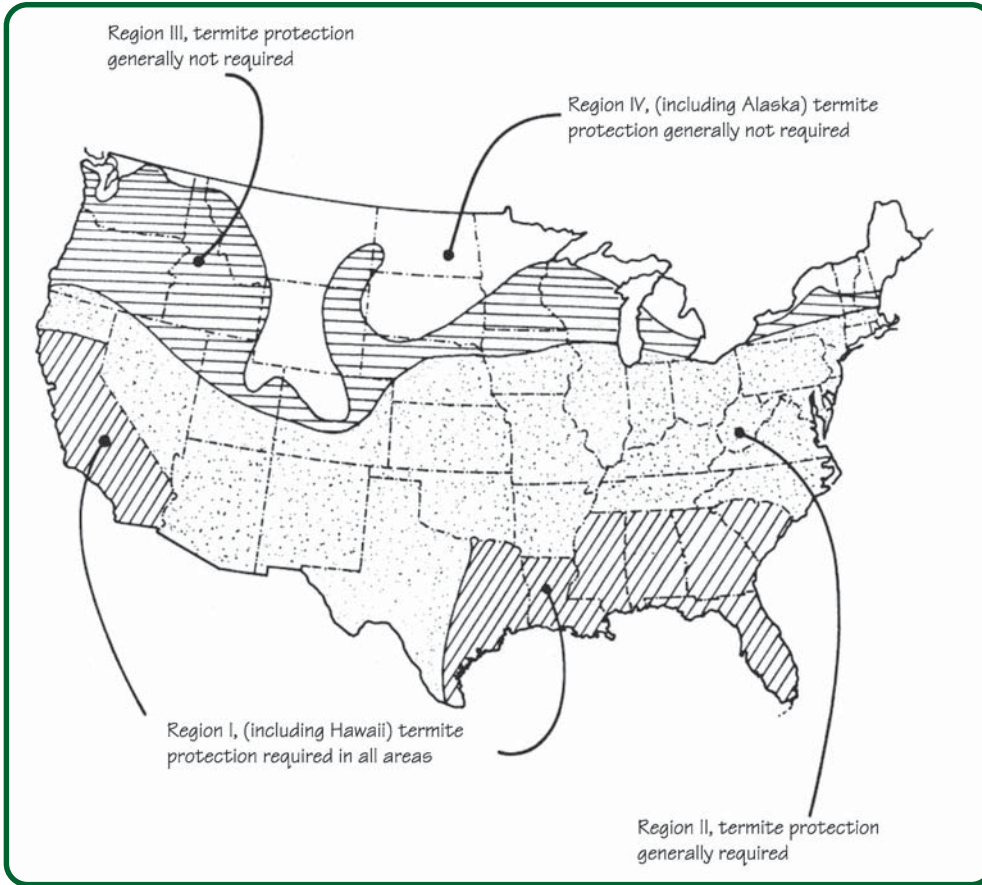

Figure 6.1 - Termite Probability (Hazard) Map

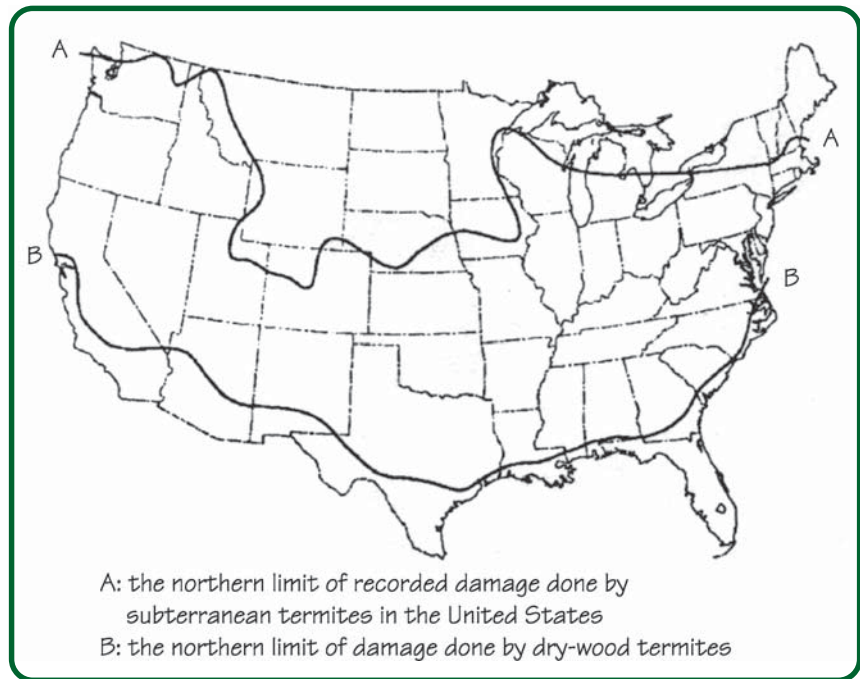

Figure 6.2 - Extent of Recorded Termite Damage

Source: Wood Handbook, USDA - Forest Products Laboratory, Madison, WI, 2000.

Soil treatments are the most common form of termite control used by the building community. Commercially, there exist about a dozen soil treatments that, by various biological means, kill termites or repel them. Termiticides are generally preferred over repellents.

Termite baits are encapsulated termiticides designed to lure insects to the bait, be eaten, and then killed. The poisons are designed to act slowly so as to not repel the insect and to facilitate the consumption and transport of the poison to the nest. Other termites ingest the termiticide from the insects that feed directly on the baits through secretions emitted by the original feeders.

Application

Chemical soil treatments are generally applied to the soil around the foundation of a home to act as a shield against termites. The treatments are performed prior to pouring the slab or foundation, shortly after foundations and slabs are poured, and at periodic intervals for the life of the structure. Directions vary according to the chemical used, but these locations are of special concern for chemical application:

- § Soil along foundations and crawl spaces;
- § Areas of soil disturbance such as bath traps;
- § Soil under appurtenances such as attached slabs and porches;
- § Soil in inaccessible or concealed spaces; and
- § Soil in proximity to slab or foundation penetrations due to plumbing, wiring, etc.

Termiticides are applied by one or more of the following methods: trenching around a foundation and flooding the trench with a sprayer; inserting a rod at periodic intervals around a foundation and injecting the chemical in the soil; and drilling holes in masonry slab or foundations and injecting the chemicals into the soil through the holes. Factors such as access to targeted areas, presence of landscaping, and the chemical employed dictate the treatment option used by the pesticide applicator. A certified pest control operator (PCO) is required for application of most termiticides.

Performance of termiticides varies considerably with climate, soil type, structure design, and homeowner practice. Locations with frequent precipitation, impermeable or very permeable soils, or great soil disruption from landscaping activities will require frequent re-application in order to maintain termite-resistive properties.

Termite baits are applied to the ground at intervals around the home as prescribed by the product label. Some bait systems employ only a

cellulose bait that requires frequent monitoring. Once termite activity is detected, a poison is inserted into the bait housing. Other bait systems contain both termite lure and poison in one formulation. The key to satisfactory performance in a bait system is proper monitoring and placement. Do-it-yourself termite bait kits are available to the general public, but the temptation is to purchase too few and monitor the baits infrequently, thus severely hampering their effectiveness. Many pest control operators offer bait systems which better assure proper bait placement and monitoring.

Re-application and Inspection Services

Chemical termiticides have a limited life because of leaching or chemical degradation. In addition, homeowner activities such as disruptive landscaping tend to limit the effectiveness of chemical treatments. Therefore, many homeowners opt to employ a termite service offered by pest control operations.

Typically, a contract with a PCO involves an initial treatment of the structure with a chemical termiticide or bait system, followed by an annual inspection of the structure with periodic retreatment performed when required. Many PCOs offer warranties that provide free retreatment if infestation is detected. Few offer warranties that pay for repair or replacement of termite-infested materials.

The benefits of an inspection and treatment service include periodic inspection of a home by knowledgeable technicians and quick remedial action when infestation is detected. A client can be better assured of a competent applicator if the PCO is a member of the National Pest Management Association (NPMA). NPMA promulgates the standards that constitute proper treatment of buildings.

6.2.2 Recommendation #2: Termite Shield

A termite shield is placed between a masonry foundation and wood framing to prevent termites from gaining access to the wood framing components. Termite shields (Figure 6.3) must be of termite-resistant materials such as metal or concrete. Some termites are able to chew through plastics and thin metals. Also, any seams in a termite shield must be soldered or otherwise sealed. Since termite shields require a high degree of care in installation, they are best used in combination with soil treatment. They should always be used when there are potential hidden pathways. Construction types known to create hidden pathways for termites

include slab-on-grade (except monolithic slabs of good construction), masonry construction, and brick veneer construction.

Hidden pathways allow termites access to wood materials through pathways that cannot be detected during periodic inspection. When there are no hidden pathways in construction, subterranean termites can be easily detected by the presence of shelter tubes or tunnels that are made of mud to protect them from light and keep them moist. Because termite shields are difficult to install on slab-on-grade construction or split-level construction, other methods of termite protection (e.g., soil treatment) are generally preferred for these types of foundations. It is also noteworthy that termites can gain hidden access through cracks as small as 1/32-inch wide. Therefore, if concrete is used as a barrier to termites, it should include welded wire fabric or sufficient reinforcement to control cracking. Examples of concrete as a termite barrier are illustrated in Figure 6.4.

6.2.3 Recommendation #3: Termite-Resistant Building Materials

Wood can be protected against termite damage by use of preservative treated wood (e.g., CCA or Borate). Using treated lumber to frame a home can add as much as \$3,000 to the price of a typical home. Such a drastic measure, however, is only used in particularly severe termite hazard areas like Hawaii.

As an alternative, preservative-treated wood may be used in isolated locations such as foundation sills and floor framing directly above the foundation. This practice is particularly appropriate for crawl space construction and for basement construction when ceilings are finished such that these elements are not easily inspected for infestation. Alternatively, naturally decay-resistant wood (e.g., heartwood of redwood and eastern red cedar) may be used, but at even greater expense than preservative treated lumber. For this reason, materials such as galvanized cold-formed steel may be a cost-effective alternative and are frequently used in Hawaii to complement or compete with the use of preservative treated wood. Concrete and masonry building materials are favored alternatives in areas such as Florida.

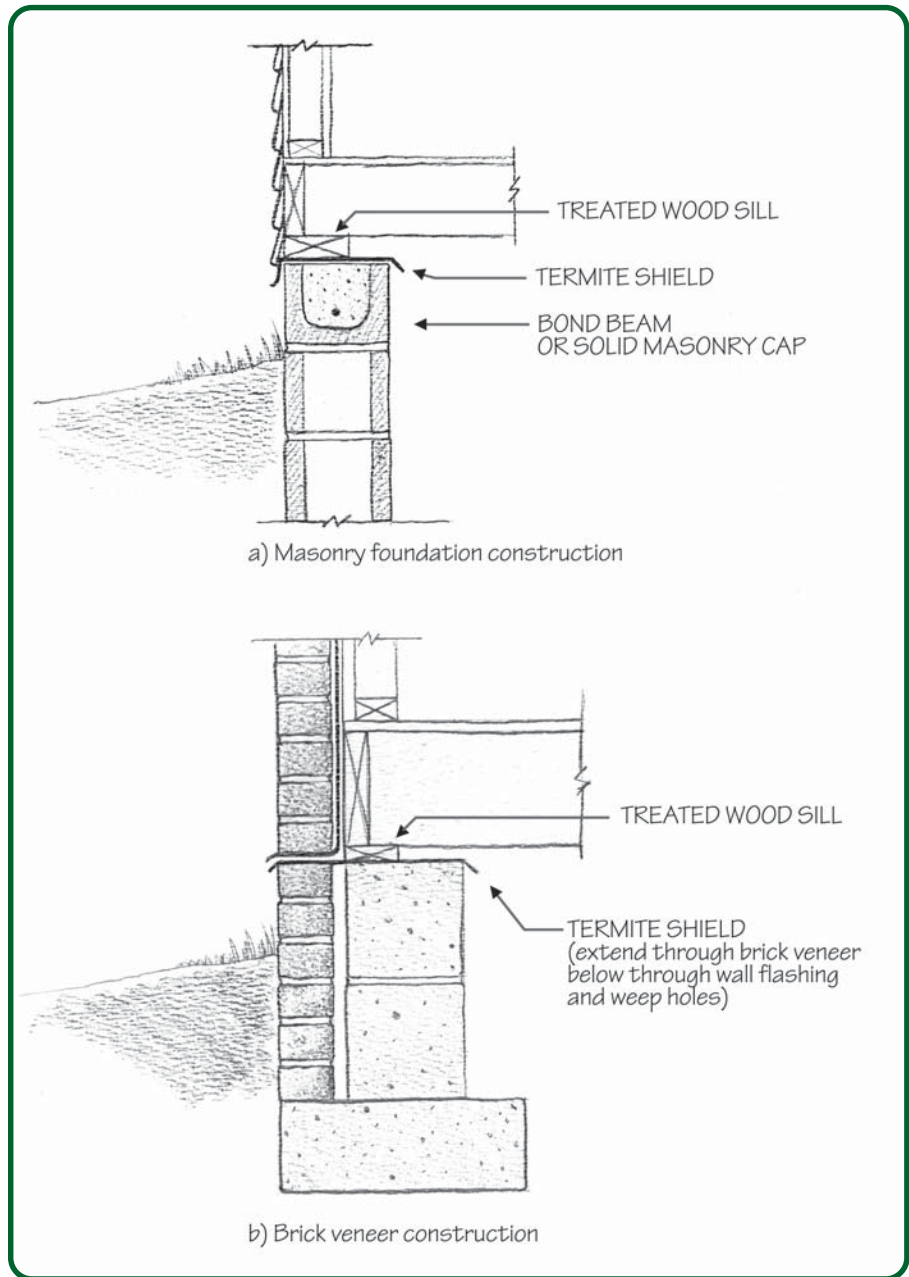

Figure 6.3 - Use of Termite Shields

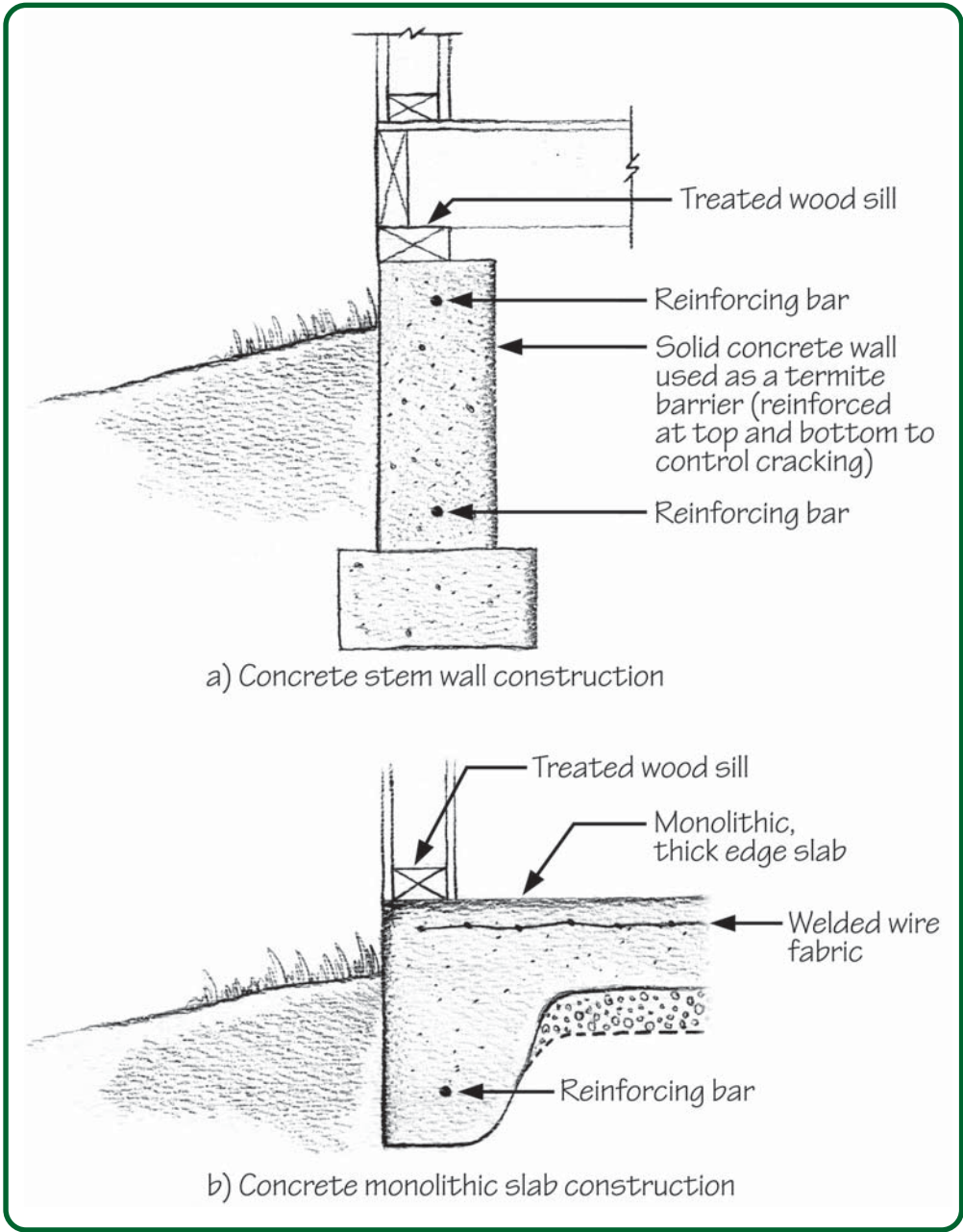

Figure 6.4 - Use of Concrete as a Termite Barrier

CHAPTER 7 - Protection Against Decay and Corrosion

7.1 General

At a moisture content of greater than 25 percent, wood is subject to fungal attack or decay. Decay will be rapid when the temperature is in the range of 70 to 85°F. The potential for wood decay when exposed to the outdoors, therefore, varies in accordance with climate (refer to Decay Hazard Map, Chapter 4, Figure 4.3). However, wood exposed to excessive moisture within any building wall in any climate, particularly one with a low drying potential (refer to Chapter 4), will grow mold and rot.

As it is for termites, wood is a food source for certain molds when conditions are right. Therefore, it is generally recommended that untreated wood be maintained in conditions where the moisture content does not exceed 20 percent.

There are essentially three options for preventing wood decay:

- § Protect (or separate) wood from moisture;
- § Use naturally decay-resistant wood; or
- § Use preservative treated wood.

Of equal concern to the exterior use of wood material is the corrosion resistance of fasteners that must hold wood joints firmly together. Finally, it is important to consider cost-effective alternatives to wood that offer potential durability and maintenance benefits. In combination with measures presented earlier in this guide, particularly Chapter 4, recommendations in the following section should address all of the major concerns regarding durability of wood construction.

Naturally decay-resistant wood species include black locust (often used as fence posts) and heartwood of baldcypress, redwood, and cedar. Due to cost and scarcity of these wood materials, however, preservative treated wood is generally the favored choice unless aesthetics demand otherwise. Of

course, alternatives to wood such as concrete, masonry, or steel construction may also be considered.

7.2 Recommended Practices

7.2.1 Recommendation #1: Separation from Ground

One of the oldest and most trustworthy practices to prevent wood decay is separation from constant uptake of moisture from the ground. In most normal outdoor exposures, wood will come to an equilibrium moisture content of less than 20 percent, although short periods of greater moisture content can occur. When enclosed in building construction, the moisture content of wood will typically reach equilibrium with the surrounding environment at a moisture content of 8 to 12 percent. However, in constantly damp locations or in conditions of extremely high humidity, the moisture content will increase up to the saturation moisture content of wood (approximately 30 percent). In most cases, this condition is related to the lack of adequate separation from ground moisture. Damp conditions can occur when wood is in direct contact with the ground or when wicking through other materials such as concrete or masonry occurs. Some well-known, code-required details for separation of wood from ground moisture are shown in Figure 7.1. If this separation is not possible, and as a reasonable precaution in all cases, wood sills and other members in direct contact with the ground or concrete/masonry near the ground level should be preservative treated.

7.2.2 Recommendation #2: Exterior Wood Protective Finishes

Another method for protecting wood from moisture is to apply a protective wood finish. The options for exterior wood finishes are wide ranging and include the following options:

- § Natural weathering
- § Water repellents
- § Water repellent preservatives (pigmented and non-pigmented)
- § Pigmented penetrating stains (semi-transparent)
- § Solid color stains
- § Paints

Outside of aesthetic preferences, the choice of the best finish and its effectiveness will depend on the type of wood, its surface condition, and the climate, among other factors. For example, the smoother a wood surface, the less effectively a finish will adhere or penetrate. Boards with a vertical or edge grain (i.e., cut radially across the growth rings of a log) result in much more durable finishes than the more common flat grain (i.e., cut tangentially to the growth rings) for reason of differences in tendency to shrink, swell, and cup (warp). Edge grain lumber also weathers better than flat grain. The more dense a wood is, the less effectively a finish will adhere or penetrate. Hardwoods often require special preparation due to pores in the wood. Finish

life is decreased because of high shrink-swell potential in moist environments. However, in protected environments (such as interior flooring) hardwood floors are known for their beauty and durability. In all cases, the moisture content of the wood must be sufficiently low (i.e., less than 20 percent) to allow for proper application of a durable and effective exterior finish. Wood composites (including veneers such as T1-11) that have the potential to swell require special protection from moisture and should not weather naturally.

Exterior wood finishes require vigilant, periodic maintenance. However, in normal climate conditions, a good exterior wood paint finish should last up to 10 years and stains for as long as 5 years before diminished function or appearance. Water repellents and water repellent preservatives generally require more frequent retreatment, but the treatment effectiveness and longevity improves as the wood weathers and becomes able to absorb more of the treatment. Penetrating stains also experience this effect and will increase in effectiveness during the second and subsequent treatments, with service life extending to as much as 10 years between treatments.

The most important factors to consider are:

- § Choosing the most appropriate and cost-effective wood material;

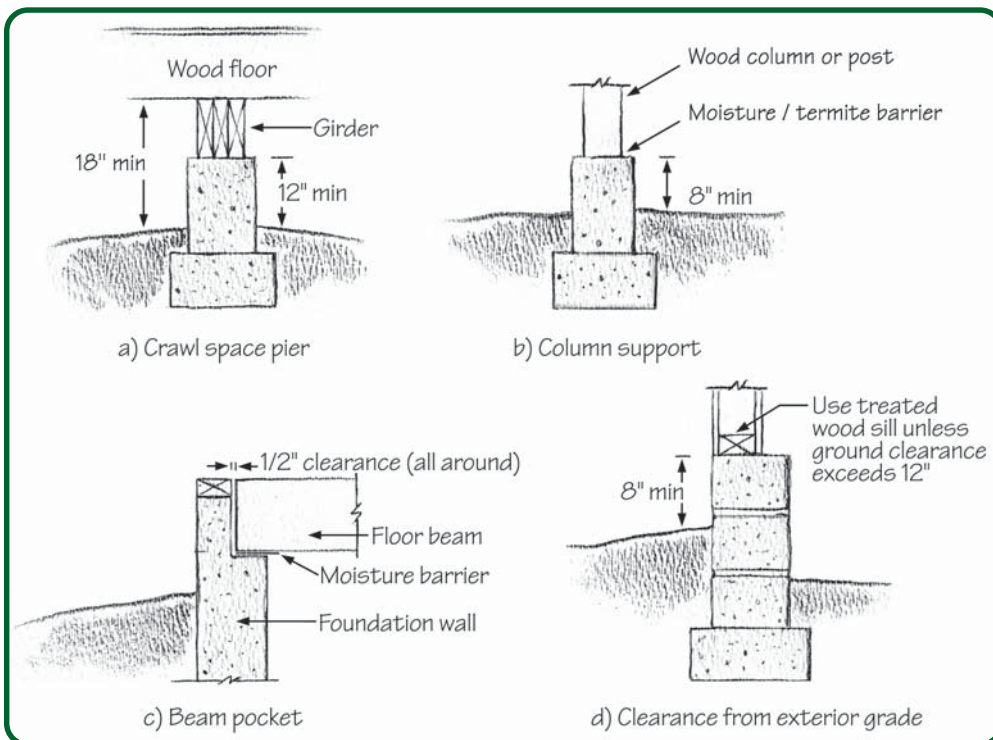

Figure 7.1 - Details to Separate Wood from Ground Moisture

- § Matching the selected wood material with a compatible finish;
- § Applying the finish properly; and
- § Educating the owner on the need for periodic maintenance.

All of these factors will not be very effective without proper moisture control, particularly for natural (untreated) wood siding and trim materials. Refer to Chapter 4 for guidance on measures for moisture control with specific interest in the use of weather barrier construction, vapor retarders, flashing, and overhangs. Overhangs are important in that they modify the exposure that siding and trim materials will experience, and enhance the service life of the finish.

The types of performance problems that may be experienced with finishes when the above factors are not appropriately addressed include:

- § Moisture penetration
- § Mildew
- § Wood pigment staining (bleed through)
- § Peeling
- § Blistering
- § Checking
- § Cracking and alligatoring
- § Excessive chalking

There are numerous types of paints, stains, and preservatives with varying cost and performance. It is beyond the scope of this guide, however, to go into great detail about the various products. Neither does this guide address special considerations regarding the repainting of wood or painting of other materials, such as galvanized or plain steel. Refer to the following references for a more detailed treatment of exterior and interior wood finishing:

- § *Finishes for Exterior Wood* (Forest Products Laboratory, USDA, 1996); and
- § *Builders' Guide to Paints and Coatings* (NAHB Research Center, 1993).

The recommendations given in Table 7.1 are intended to give the best exterior finish results for typical conditions and a wide variety of wood materials commonly encountered in home construction and exterior finishing applications.

Judging Paint Quality

The quality of paint is generally determined by the following factors and is usually correlated to price:

- § High solids content,
- § Low ratio of pigment to vehicle, and
- § Type of binder or vehicle.

Unfortunately not all paint labels include the above information. Therefore, consult a paint

specialist or the manufacturer for additional information; otherwise, it is generally safe to assume that cost is directly related to quality. When considering price, it is important to realize that paints with less solids content may result in the need for more coats to provide adequate coverage. Therefore, it is usually cost-effective to invest in high quality paints.

In general, low gloss or flat paints (high pigment to vehicle ratio) use more pigment content and are less durable than gloss paints; and latex acrylic paints are more flexible and resilient than oil-based (alkyd) paints. Regardless of the paint selected, application instructions provided by the manufacturer should be carefully followed for best results.

Many people falsely believe that painting wood will stop decay. In fact, painting wood that has already begun to decay can trap moisture and promote decay. Paint is primarily used as an aesthetic finish that also serves to protect wood from intermittent wetting (as from rain) and weathering from sunlight (UV radiation). A good quality (moisture resistant) paint will help to moderate the moisture swings through which exterior wood would otherwise be exposed. If frequent wetting occurs to painted wood, it may even be more likely to decay than unpainted wood if not properly maintained, particularly at end joints of lumber trim, siding, and window and door casings.

Wood absorbs moisture nearly 30 times more rapidly through the end grain than through its sides. If moisture is absorbed, painted wood will tend to dry slower than unpainted wood and accelerated rotting can occur near end joints. Therefore, it is always a good practice to keep joint designs simple and to pre-treat all end joints with a water repellent preservative prior to installation and finishing.

TABLE 7.1 - RECOMMENDED FINISHES FOR EXTERIOR WOOD

Wood Material	Applications	Finish Recommendations (Preferred option is bold) ¹	Special Enhancements
Untreated (natural) wood	Siding, Trim, Railings, and other items not in ground contact	Paint: Prime all sides with acrylic latex stain blocking [†] primer Apply two coats of all-acrylic latex house paint ⁴ <u>Opaque stain (latex)⁵:</u> Use same procedure for paint (best for rough surfaces).	(a) Treat end joints with a paintable [†] water repellent preservative; allow 2-3 days to dry prior to painting; (b) Top coats and primer should include mildew-cide
Treated wood ²	Decks, Columns, Framing, Fascia Boards, Trim	Paint: Same as above <u>Opaque stain (latex)⁵:</u> Use same procedure for paint; do not use on decking (best for rough surfaces) Semi-transparent stain: Best for wood decks and general use on treated wood; apply two coats	(a) Treated wood is usually high in moisture; let dry for several weeks prior to application of finish (b) Best if wood is slightly weathered for penetrating stain
Naturally decay-resistant wood	Siding, Trim, Decking, Columns, Framing, etc.	Semi-transparent stain: Same as above for treated wood (use decay-resistant wood) Water-repellent preservative: Apply two coats; use pigmented version if natural wood color is not desired or use semi-transparent stain for deeper color modification Water repellent: Apply two coats	Painting as for non-decay-resistant wood is also applicable; special care should be taken to make sure stain blocking primer is used.
Wood Composites ³	Siding, Trim	Paint: Same as above for untreated (natural) wood. <u>Opaque (solid color) stains⁵:</u> Same as above for paint; works best on rough surfaces such as T1-11 siding	(a) Treatment of end joints/cuts particularly important to prevent edge swelling (b) Penetrating stains and other inatural [†] finishes should not be used (c) Use of overhangs as additional protection should be considered depending on climate
General Application Recommendations:			
§ All surfaces should be clean and dry.			
§ For painted surfaces (including opaque stains) that are very smooth, the surface should be lightly wetted and allowed to dry for several days, then sanded with #50 to #80 grit sand paper.			
§ Do not apply paint when temperatures are or will soon drop below 50°F or when heavy dew is suspected prior to complete curing. Avoid painting surfaces that will soon become heated by the sun (i.e., follow the sun around the building).			
§ Closely follow manufacturer application instructions and coverage recommendations. Coverage is generally around 400 ft ² per gallon for paint and opaque stains and 200 ft ² per gallon for penetrating stain. Rougher surfaces will reduce coverage amount per gallon.			
§ Multiple coats: For penetrating stains, time between coats should allow for drying; for water repellent preservatives, time between coats should not allow drying; for paints, time between coats should allow 2 days for curing, but not more than 2 weeks.			
§ Brushed on finishes (especially using back brushing technique) will generally improve finish coverage, penetration, and/or adherence to the wood surface.			
§ Use corrosion resistant fasteners; deformed shank nails should be considered for siding and trim attachment; stainless steel nails should be considered for natural wood finishes. Use hot-dipped galvanized nails for treated wood.			
§ Use of furring behind siding to create an air gap will increase finish and wood siding service life.			

NOTES:

¹Based on a subjective consideration of general aesthetics and, primarily, durability relative to other choices.

²Treated wood refers to wood treated with water-borne preservative such as Copper Chromium Arsenate (CCA). CCA is paintable and stainable and the wood treatment can actually enhance finish performance provided the wood is dry and the surface is not very smooth or weathered. Weathering, however, does enhance the application of penetrating stain.

³Wood composites include OSB, plywood (i.e., T1-11 textured siding panels), and fiber board or hardboard. Follow manufacturer application, installation, and finishing instructions carefully when using these materials.

⁴Paint top coats are generally applied after installation, although the first top coat may be applied prior to installation on all sides, but more importantly the end grain and exposed sides. Second top coat may be omitted if coverage is sufficient and when used only on sides of the building not facing south or west; however, this may shorten the expected service life.

⁵Opaque stains are not recommended for horizontal surfaces such as trim and window sills, and it is particularly not recommended for wood decking. Opaque stains work best when applied to rough, un-weathered vertical surfaces.

7.2.3 Recommendation #3: Preservative Treated Wood

Where wood cannot be protected from moisture or where its service requirements demand resistance to constant moisture exposure, preservative treated wood must be considered for durability purposes. Untreated wood in ground contact or exposed to constant moisture in exterior above-ground applications will rot within a short period of time, generally less than two years.

The most common wood preservative treatment is Copper Chromium Arsenate (CCA). In fact, 98% of all water-borne preservatives used to treat wood in 1997 was CCA (source: American Wood-Preservation Association, Wood Preservation Statistics, 1997). CCA, which leaves wood with a light-greenish tint, has excellent decay resistant qualities when properly specified. It lasts more than 30 years without decay in exposure tests when properly treated. CCA also repels insect infestation. The most important characteristic for proper treatment is the amount of chemical that impregnates the wood and that is retained after treatment. Recommended retention levels for CCA are given in Table 7.2.

There are several other CCA-like treatments (e.g., ACQ, boric acid) that require similar levels of retention for effectiveness. It is also worth noting that CCA is not the recommended treatment for every species of wood. In the west, for instance, Douglas fir treated with CCA shows poor performance.

Some pointers to ensure good performance of treated wood are as follows:

- § Allow several weeks for treated lumber to dry before installation (it is generally wet due to the water-borne treatment process); if installed wet, fasten securely to prevent warping and back-out of fasteners.
- § For treated wood that is to be installed immediately or painted, consider specification of kiln-dried after treatment (KDAT) lumber.
- § Treat field-cut ends of preservative treated

lumber with an over-the-counter wood preservative; for thick lumber, preservative treatment does not penetrate to the middle of the member.

- § Put factory cut and treated ends in the more severe location (e.g., ends of posts in ground).
- § Use preservative treated lumber that is labeled and certified by an American Lumber Standard Committee (ALSC) inspection agency and that is treated in accordance with American Wood Preservers' Association (AWPA) standards.
- § Once dry or slightly weathered, treat exposed wood with a penetrating stain and water-repellent (unless other finishes are desired).
- § Do not use opaque stains or latex paints on deck surfaces; use only special deck paint if solid color is desired.

7.2.4 Recommendation #4: Fasteners and Corrosion Resistance

Depending on application conditions, there are several options for fastener selection. Fasteners used within a building's weather barrier are generally protected from corrosion and, therefore, do not usually require special consideration regarding durability. However, in exterior exposures, the durability of fasteners and metal connectors is a major issue. The following recommendations are intended to give reliable, long-term performance:

- § Siding nails, as well as nails in treated wood exterior framing (i.e., decks) should be galvanized (preferably hot-dipped). Bolts should also be hot-dipped galvanized rather than electroplated.
- § In particularly severe environments (e.g., exterior construction subject to salt-

TABLE 7.2 - RECOMMENDED PRESERVATIVE RETENTION LEVELS FOR CCA-TREATED LUMBER

Application	Retention (lb. per cu. ft. of wood)
Above grade (decking, trim, railings, etc.)	0.25
Ground contact (sills, posts, not in ground)	0.4
Foundations (below ground)	0.6
Marine	2.5

spray from the ocean), stainless steel fasteners and hardware should be considered, although thicker than normal galvanic coatings (i.e., G90 or higher) are acceptable. Situations in which galvanized metal fasteners, such as joist hangers, are subjected to periodic salt deposition without the possibility of rinsing from rain (e.g., under a deck) should be avoided.

- § Stainless steel siding nails are often used to prevent rust staining in any environment; deformed shank siding nails are also preferable to prevent nail back-out caused by moisture cycling of the wood.
- § Siding and roofing nails should be installed in dry wood. Wet wood, when it dries, will lose some of its holding power on the nail.

Proprietary coatings on pneumatic fasteners are available and should be used only as recommended by the manufacturer. These coatings are generally similar to electroplated galvanic coatings, but special alloys are sometimes used to enhance corrosion resistance. Mechanically coated nails are also found in the market with coating thickness and characteristics similar to electroplated galvanic coatings. Galvanic coating thickness and environmental conditions are the primary factors in determining the time until the onset of rust. Service life of nails under normal exterior conditions is shown in Table 7.3.

Other non-corrosive metals may also be available for some types of fasteners (e.g., copper or aluminum). However, aluminum and copper can be reactive with other metals or environmental conditions. For example, aluminum or copper nails should not be used with galvanized metal connectors. For best results, fasteners and attached metallic materials should always be of the same type of metal.

7.2.5 Recommendation #5: Alternatives to Wood Exteriors

As a final recommendation to prevent the decay of exterior wood, there are many new products available that serve as replacements to wood. Recently, several engineered wood composites have been introduced and subsequently encountered durability failures (see Section 2.5 ñ Common Performance Problems). This has left many builders skeptical of engineered wood products for exterior use. However, with suitable installation and climate conditions, most engineered wood products have performed well. Similarly, exterior insulation finish systems (EIFS) encountered serious problems related to durability and moisture damage. On the other hand, some products like vinyl siding and vinyl-clad or vinyl windows have been used with great success and increased frequency. Therefore, it is worthwhile for designers and builders to consider new materials that offer promise of durability or affordability, or both. Some of these products include:

- § Vinyl siding and trim products;
- § Vinyl windows and doors;
- § Plastic trim products;
- § Plastic coated foam, molded plastic, or fiberglass trim products that are UV-resistant and that are paintable/stainable;
- § Plastic lumber decking and posts;
- § Fiber cement siding and trim products; and
- § Fiber cement boards, siding, and trim.

Most of these products have been in use for some time and, if required, include UV inhibitors to protect against dry rot.

Untreated, non-decay resistant wood species exposed to the weather (without ground contact or protective coating) will generally last between 2 and 20 years depending on the severity of the climate (see Decay Index Map, Figure 4.3). On the other hand, properly treated or naturally decay-resistant wood will last more than 20 years without significant decay, almost regardless of climate.

TABLE 7.3 - NO-RUST SERVICE LIFE OF NAILS EXPOSED TO NORMAL OUTDOOR ENVIRONMENT

<u>Nail Type</u>	<u>Coating Thickness, mils (1/1000 of inch)</u>	<u>Service Life</u>
Galvanized (electroplated or mechanically plated)	0.2 (varies)	5 - 10 yrs
Hot-dipped galvanized	2 to 6	20+ yrs
Stainless Steel	N/A	50+ yrs

Although many new materials can provide desirable qualities, an old-timer with a taste for tradition may desire traditional products. In this case, the builder or the client must be willing to pay to get some of the expensive naturally-decay resistant wood products that are still available, such as straight grain red cedar or heartwood Douglas fir. Alternatively, treated wood that can be used with paints and stains may be selected. Coating manufacturer recommendations should be carefully consulted.

The most important concern is to choose appropriate siding and trim material and detailing for the climate. In severe climates (e.g., hot and humid), it may be wise to remain conservative or at least to run field tests on a shed or some other harmless application. When experimenting, purchase a moisture meter and take the time to observe the performance of the new product as well as some of your current materials and methods. It is always best to run side-by-side comparisons of identical buildings. Alternatively, you may receive some help in performing your own tests or certified laboratory tests by calling the ToolBase Hotline at 800-898-2842 or sending your request for information to askanexpert@nahbrc.org. ToolBase is a service of the NAHB Research Center and is sponsored by NAHB, CertainTeed, HUD, the North American Steel Framing Alliance, the Wood Truss Council of America, the Wood Promotion Network, and others.

CHAPTER 8 - Natural Hazards

8.1 General

Severe damage to homes is often seen in media reports following major natural disasters, such as Hurricane Andrew in Florida and the Northridge Earthquake in California. As a result, the most prevalent (and less interesting) forms of damage that have common sense fixes are rarely given the degree of consideration they deserve.

From past scientific surveys of hurricane damage, it can be seen that damage to roofing and water damage to contents are the most frequent and costly repairs. For example, damage statistics for Hurricane Andrew and Hurricane Opal (Florida) are shown in Table 8.1. It can be seen that the most significant forms of damage were associated with roofing loss. In Hurricane Andrew, a particularly severe Category 5 event, roof sheathing loss and window breakage were also prevalent. Since the data presented in Table 8.1 was collected using a random sample of the housing stock in each event, the findings approximately represent the overall housing stock performance.

Light wood-frame homes are well-known for their resiliency in earthquake events as evidenced by the low frequency of collapse, even in extreme earthquakes. However, because homes are the most common type of structure, they account for much of the overall damage, but usually in the form of cracked interior and exterior finishes. As shown in Table 8.2, more serious forms of structural damage to foundations and walls are a relatively rare occurrence.

Based on the above data, which identifies key issues related to durability of homes in natural disasters and places them in the proper perspective, the following section gives some recommended practices to improve performance at a modest cost. Other forms of disaster include wildfires, hail, tsunamis (tidal waves), etc. For fire resistance, fire resistant siding and roofing materials as well as landscaping that reduces fuel sources near to the home may be used. For hail, resistant roofing products, such as tile or specially rated asphalt shingles, may be considered. Properly installed metal roofing is also a good option for wind, hail, and fire resistance.

TABLE 8.1 - HURRICANE DAMAGE STATISTICS (SINGLE-FAMILY HOMES)

Component	Frequency of Moderate to Severe Damage (% of all homes)	
	Hurricane Andrew [165 mph gusts]	Hurricane Opal [100-110 mph gusts]
Roof sheathing	64%*	2%*
Walls	2%	0%
Foundation	0%	0%
Roofing	77%	4%
Interior finish	85%	Unknown

Sources:

(1) NAHB Research Center, Inc., Assessment of Damage to Single-Family Homes Caused by Hurricanes Andrew and Iniki, U.S. Department of Housing and Urban Development, Washington, DC, 1993.

(2) NAHB Research Center, Inc., Assessment of Damage to Homes Caused by Hurricane Opal, prepared for the Florida State Home Builders Association by the NAHB Research Center, Inc., Upper Marlboro, MD, 1996.

*Percent value of homes which lost one or more roof sheathing panels.

**TABLE 8.2 - NORTHRIDGE EARTHQUAKE DAMAGE STATISTICS
(PERCENT OF SINGLE-FAMILY HOMES)**

Component	No Damage	Low Damage	Moderate Damage	High Damage
Foundation	90.2%	8.0%	0.9%	0.9%
Walls	98.1%	1.9%	0.0%	0.0%
Roof	99.4%	0.6%	0.0%	0.0%
Exterior finish	50.7%	46.1%	2.9%	0.3%
Interior finish	49.8%	46.0%	4.2%	0.0%

Source: NAHB Research Center, Inc., *Assessment of Damage to Residential Buildings Caused by the Northridge Earthquake*, prepared for the U.S. Department of Housing and Urban Development, Washington, DC, 1994.

8.2 Recommended Practices

8.2.1 Recommendation #1: Hurricane-Prone Areas

The following recommendations will assist in improving the durability of homes in areas prone to frequent high winds resulting from tropical storms or hurricanes:

- § Nail roof sheathing according to manufacturer's fastening schedule, using pneumatic or hand driven 8d deformed shank fasteners or screws.
- § Use the 16-nail method for attaching 3-tab roof shingles; make sure the roof deck is dry prior to installation; follow installation instructions on the packaging.
- § Apply roofing cement (mastic) to the underside of shingle tabs along the roof perimeter and ridge.
- § Use 15# felt roofing underlay and flashings as shown in Chapter 4.
- § Use moderate sloped roofs of 4:12 to 6:12 to minimize wind uplift while avoiding large lateral loads on the building; in general, hip roofs perform better than gable roofs.
- § Consider low-profile plans (i.e., a one-story home is less vulnerable than a two-story home).
- § Use hurricane ties or clips to attach the roof to the walls; in severe coastal exposures make sure that the load transfers either through the sheathing or through additional brackets down to the foundation; it doesn't take much effort or hardware to make a big difference.
- § If building on the beach, elevate the house above the local base flood elevation and set-back as far as possible from the coastline;

expect damage at some point in time if coastal exposures are quite threatening in hurricane-prone regions.

- § Use the services of a knowledgeable design professional for complex or non-conventional plans; make sure the detailing is clearly shown on the plans or construction shop drawings prior to the start of construction.

8.2.2 Recommendation #2: Earthquake-Prone Areas

For areas prone to earthquakes, the following practices may be used to improve durability:

- § Use continuous wood structural panel sheathing on all exterior walls.
- § Avoid stucco and similar brittle exterior finishes (cracks will be apparent and require repair in moderate to strong events and may also leak in future rain); however, stucco can provide a very stiff and strong building that also minimizes interior finish cracking in moderate earthquakes.
- § Avoid steeply sloped sites or sites with soft soils that may liquefy during ground shaking.
- § Consider low profile plans (i.e., one-story instead of two-story home).
- § Avoid heavy roofing materials.
- § Use the services of a knowledgeable design professional for complex or non-conventional plans in hazardous earthquake regions.

- § Secure heavy equipment such as water heaters and storage tanks and use flexible gas lines to natural gas appliances.
- § Advise homeowners to secure furnishings, such as bookshelves and wall hangings, to prevent damage or injury.

8.2.3 Recommendation #3: Inspection

Generally, connections are a key area where wind damage occurs and, to a lesser degree, earthquake damage in single family homes. Care should be taken to inspect for the proper connection of roof and wall sheathing, as well as any required brackets or metal connectors. In high wind areas, inspection of roof sheathing nails into a gable end truss (gable roof) is particularly important. To obtain thorough inspection, some builders and designers include special inspection services within the scope of contracts as a matter of business practice.

To assist builders and framers in obtaining the maximum level of quality possible, the NAHB Research Center has initiated the Framing Quality Assurance Program (1-800-638-8556). The program is ISO 9000 based and requires adoption of effective quality procedures as well as periodic auditing by a third party.

8.2.4 Recommendation #4: Flood-Prone Areas

Flood-prone areas include many coastal zones subject to storms as well as land near waterways that periodically experience flooding. A few simple design considerations for these areas that can increase house durability include:

- § Install components like HVAC blowers, electrical receptacles, and hot water heaters at elevated locations in basements. This practice can make recovery easier and less hazardous.
- § Consider the use of back-flow restriction valves to reduce the risk of sewer water backup into houses during flood events.
- § Do not build in the 100-yr flood plain or follow appropriate construction guidelines and regulations for flood-resistant construction (i.e., elevated foundation).
- § Do not use moisture-sensitive building materials and finishes below the first above-grade floor.

CHAPTER 9 - Miscellaneous

9.1 General

The previous chapters of this book have dealt with significant durability issues that can impact the functionality and livability of a home. There are other durability-related issues in homes that do not necessarily increase the risk to the structure or the occupants, but which, nevertheless, are often quite important to occupants. The presence of these nuisance items often leads to perceptions of poor quality and durability. The consumer is no less concerned with these nuisances than a leaking window caused by improper flashing or a damp basement caused by inadequate site drainage. Nuisances include items such as nail pops or premature wear of a product or surface. This chapter focuses on how to address expectations when dealing with some of the more common problems in this category.

One of the largest obstacles to overcome is separating normal wear and tear from premature wear. As in other parts of the home, this requires understanding and managing expectations. For example, carpets, paints and other interior finishes are generally expected to wear out over time. Although there are certainly better grades of these products, they often come with a higher cost. In other words, consumers need to understand that they usually get what they pay for when selecting finish materials. Because there is some amount of personal choice involved in selecting finish materials, this document does not attempt to prescribe one type of product over another. However, where appropriate, some options are identified where different types of finishes may prevent premature wear or prevent common problems with finishes.

Recommendation #1: High Traffic Areas

Use wear-resistant surfaces in high traffic areas. Bathrooms, kitchens, and entryways face more severe exposure than other areas of the home. Old standbys like tile, hardwood, and vinyl certainly are good products for some of these areas. Also consider some of the new laminates that give the

look of wood but which have better resistance to wear and scratches. A newer trend that appears to be growing is the use of stained or pigmented concrete floors.

Recommendation #2: Finish Selection

Select finishes and colors that can mask dirt in high traffic areas. In addition to wear in high traffic areas, keep in mind that darker colors are better at masking dirt carried in from outside. Although nearly all carpets today are better at resisting stains, evidence suggests that lighter colors contribute to complaints about carpet soiling (see next section).

Recommendation #3: Carpet Soiling

Carpet soiling is a phenomenon where soils, combustion particles, and other particulates accumulate at the base of walls, under interior doors, and other areas. The result is dark, linear stains along these surfaces. In the most severe cases, it cannot be removed by cleaning. Carpet soiling can be minimized through the use of darker carpet colors, multiple return-air grilles (as opposed to central returns), passive returns or jump ducts from bedrooms, and occupant education about the implications of using candles in the home.

Recommendation #4: Stuck Windows

Windows and doors can stick or be difficult to open and close for a number of reasons. Problems typically result from the swelling of framing around openings or excessive deflection in headers.

One way to reduce header deflection is to size the headers with sufficient stiffness. It is important to recognize, however, that even with proper sizing, temporary deflection and even permanent deflection can occur and possibly interfere with window operation. A common practice that contributes to

inoperable windows is shimming between the window frame and the header. This space should be left open to allow for deflection of the header.

To avoid the swelling of materials and subsequent problems with the operation of doors and windows, the entry of water must be prevented by the use of proper drainage and flashing details. It is very important to ensure that siding is installed according to the manufacturer's specifications. Do not assume that the same details that work with one type of exterior finish will work with others or that all windows or doors are the same with respect to the frame's water tightness.

Finally, when using an air-sealing foam to plug air leaks around window frames, use low-expansion foams that don't deflect the frame as they expand and harden. Non-expanding products, such as caulk or fiberglass, can be used instead. However, some window manufacturers void their warranties if such products are used around their window frames.

Recommendation #5: Nail Pops and Drywall Cracks

Cracks, visible seams, and nail pops are some of the most common interior finish complaints lodged by homeowners. Although it can't be guaranteed that a home will be immune from these problems, some strategies can be adopted to minimize their chances of occurring. One strategy calls for developing specifications for drywall and framing contractors that clearly outlines expectations. Another equally important strategy is follow-up supervision of contractors. During construction, consider adopting the following:

- § Install finishes only to sufficiently dry lumber (i.e., 12% moisture content or less) and use a moisture meter to check conditions.
- § Heat homes and keep humidity low to limit chances that joint compound will cure either too quickly or slowly and cause seams to crack.
- § Reduce shrinkage that causes nail pops and cracks by specifying only kiln-dried lumber.
- § Hang drywall to minimize joints directly at the ends or over headers or other openings.
- § Consider stiffer floor and ceiling framing to minimize deflection that can create cracks along seams.
- § Use two-stud corners and drywall clips to minimize cracks at outside corners.

- § When installing drywall on ceilings, float (i.e., do not fasten) the ends of the sheets at wall intersections. This will avoid cracking if the trusses move.

Recommendation #6: Floor Squeaks

Noisy floors are one of the most common callback problems for builders. Floors, like other parts of a home, are subject to movement. The most typical noise is related to loose nails or other fasteners that squeak when a person walks across the floor. Sometimes, noise is the result of movement of the floor sheathing when attachment is insufficient (too few fasteners) or when the sheathing is not pulled tight to the joist. In other cases, fasteners that miss the floor joist below and end up alongside the joist create noise when the joist deflects and the nail rubs against it. Recommendations include:

- § Use only kiln-dried lumber, which is marked iKD.†
- § Install the correct number, spacing, and type of fastener into the sheathing. Specify these items to your trade contractor.
- § Consider screws or deformed shank nails as opposed to smooth shank nails to reduce movement of the fasteners.
- § Consider the use of adhesives to help limit sheathing movement. Adhesives can stiffen the floor and reduce bounce. But be careful— an adhesive that sets up too soon (e.g., in cold weather applications) can contribute to squeaks by preventing the sheathing from pulling tight to the floor joists.

Recommendation #7: Subfloor Material

Select subfloor material keeping in mind the finished floor, the tolerance of the flooring for unevenness, and the expected weathering that the subfloor will experience during construction. One option is to use special moisture-resistant oriented strand board (OSB) subfloor sheets to reduce edge swelling when exposure to moisture during construction is unavoidable.

Recommendation #8: Paints and Corners

Consider application-appropriate paints to keep walls fresh looking. Glossy paints are easier to clean and should be considered for use on doors, trim, and other high traffic areas. Flat or matte finishes give a softer, more appealing texture for interior wall surfaces while hiding imperfections. Fortunately, there are now paints on the market that come with a flat finish but are washable. These make a great finish in areas such as kitchens, mud rooms, bathrooms, and children's rooms when a flat look is desired.

Also, consider the durability of wall corners to reduce dents, chips, and other damage by occupants by using prefabricated corners to aid in damage reduction. For more information about available products, see the PATH website at www.pathnet.org.

9.2 Plumbing

Recommendation #1: Pipe Material

Choose the right plumbing material for the water supply and local conditions. In most locations of the United States, copper and plastic (e.g., CPVC) are viable products. But sometimes, one is advantageous over the other. It is often advisable to check with local plumbers and code officials to determine if there is a history of local conditions that would lead to a preference for a certain material. For example, are there reports of aggressive soils or water that may attack the material?

Recommendation # 2: Washing Machine Leaks

One of the leading causes of insurance claims is water damage from burst washing machine hoses. With the trend toward finished basements and the increasing placement of laundry areas on main floors and second floors, the potential for damage is increasing. Simple tools to remind homeowners to inspect/replace hoses (e.g., magnets with inspection schedules to fill out) are available. Care should also be taken to address drainage in case a leak occurs. A drainage system and catch basin large enough to accommodate the washing machine and the area surrounding the hose connection is always recommended. When replacement hoses are purchased, high quality hoses should be selected.

Recommendation # 3: Frozen Pipes

In cold climates, protect water pipes against freezing. The best approach is to keep all water pipes within the thermal envelope. This becomes difficult in vented, unconditioned crawlspaces where risers may need to be insulated and operable vents should be closed in the colder periods of the year. Alternatively, an insulated, unvented crawlspace can be used (see Section 4.2.6).

Recommendation #4: Plumbing Units

Select certified kitchen and bath fixtures to reduce the possibility of premature failure. Tubs, sinks, shower stalls, and countertops of every type and grade should meet some minimum standards to prevent chips, cracks, leaks, or excessive wear and tear. Look for the NAHB Research Center label or other label from a reputable quality assurance agency that lists these products.

Recommendation #5: Bath Room Design

Consider use of seamless tub and shower units to reduce reliance on sealants. Inspect for leakage around bathroom fixtures and replace seals and sealants as required. Use cement-based backer board behind tile finishes.

9.3 HVAC

The issues with HVAC systems primarily relate to comfort, and in a few cases, potential moisture problems. As a side benefit, actions taken to address these issues generally tend to improve the energy efficiency of the home.

Recommendation # 1: Duct Leakage

Leaky ducts can lead to a host of problems ñ dry air, humid air, condensation, among others. The problems that can occur depend on the location of ducts and the climate. The safest bet is to simply build tightly sealed duct systems. Tight ducts will alleviate potential problems and increase the efficiency of an HVAC system. Designing the home with the duct system entirely within the thermal envelope also helps to head off problems.

Recommendation # 2: House Air Leakage

Keep air infiltration through cracks in the building envelope to a low level. Like a leaky duct, a leaky structure also brings in outdoor air and can result in uncomfortably dry indoor conditions during the heating season. Air sealing is becoming a more common component of the energy package for homes and is an effective practice with or without the inclusion of a separate air barrier (i.e., building wrap). But, be aware that an aggressive approach can make a home too tight, which results in the need for supplemental ventilation. A blower door test can be performed to estimate the air infiltration rate.

Recommendation # 3: Load Sizing

Use proper methods such as Air-Conditioning Contractor's Association (ACCA) Manual J (software version is called Right-J) for determining design heating or cooling loads and HVAC equipment sizes. Rules of thumb for sizing should not be used.

Bigger is not always better! Oversized equipment can lead to moisture problems since the air-conditioner may not run long enough to adequately dehumidify indoor air during summer cooling months.

Recommendation # 4: Exhaust Ventilation

Use exhaust fans in all full bathrooms and near other moisture sources in the house, such as kitchen ranges. With larger floor plans and more interior-room bathrooms in homes, moisture from showering has no place to go without an exhaust fan.

Bath fans are often rated for a specific flow at 0.1 \hat{w} c. This static pressure roughly correlates to an air grille, five feet of 3-inch flex duct, and an end point cap. As-built installations are commonly more extensive than this, and static pressure levels are greater. Therefore, fans will often exhaust as little as 0.05 of their rated capacities due to long duct runs, hoods, and grilles. It is often advisable to select a fan based on airflow at 0.25 \hat{w} c. Rated flow is usually listed on the fan packaging, or consult manufacturer's literature. Alternatively, use of a 4-inch or larger diameter fan duct will result in improved air flow in comparison to standard units with 3-inch diameter ducting. Also, rigid metal duct is less restrictive than flex duct.

9.4 Exterior Finishes

Recommendation #1: Drainage

Provide positive drainage away from patios, sidewalks, driveways, and other concrete flatwork to reduce frost heave and other water-related damage. Drainage starts with a solid base/subgrade and ends with proper grading at a 2% or greater slope...air-entrained concrete can also help improve durability.

Recommendation # 2: Siding Installation

Check siding for appropriate installation to avoid buckling. Vinyl and metal sidings expand and contract from changes in temperature. Nearly all of these products should not be nailed or screwed tight to the structure, but rather, they should be hung from the nail or screw to allow for movement. It is also important to leave room where the siding abuts channels or corner trim. When properly installed, each piece of siding should be able to move sideways and up and down slightly.

A problem that commonly occurs with horizontal siding is buckling at rim joists as a consequence of shrinkage of the large dimension lumber. To avoid potential callbacks, consider engineered wood (i.e., OSB) for rim joists. If engineered wood rim joists are used, however, special details for anchoring decks to the house must be used because the web section of many engineered wood joists is not suitable for this purpose.

Recommendation # 3: On-Site Conditions

Protect doors, floor sheathing and other products against delamination or swelling by keeping them protected from the elements when stored at the job site. This practice addresses long-term problems that are not immediately noticeable, such as slight bumps in the floor at cut edges of sheathing that cause increased, localized wear of floor coverings. Other problems that result from site conditions can become noticeable very quickly. Examples include warping of wood products, staining or mold growth, and weakening of some materials.

The best approach is to minimize exposure of sensitive products to the elements. Inspect materials for pre-existing damage when they arrive on site. Stage construction so that sensitive materials are covered as soon as possible or provide a dry storage area for these products.

Bibliography

General

ASHRAE 1985 Fundamentals Handbook, American Society of Heating, Refrigeration, and Air-Conditioning, Inc., Atlanta, GA, 1985.

ASHRAE 1993 Fundamentals Handbook, American Society of Heating, Refrigeration, and Air-Conditioning, Inc., Atlanta, GA, 1993.

ASHRAE 1997 Fundamentals Handbook, American Society of Heating, Refrigeration, and Air-Conditioning, Inc., Atlanta, GA, 1997.

Structures and Environment Handbook, Eleventh Edition, Midwest Plan Service, Iowa State University, Ames, Iowa, 1983.

Residential Structural Design Guide, 2000 Edition, U.S. Department of Housing and Urban Development, Washington, DC, 2000.

Prevention and Control of Decay in Homes, U.S. Department of Housing and Urban Development, Washington, DC, 1978.

Wood-Frame House Construction, Agriculture Handbook No. 73, U.S. Department of Agriculture, Forest Service, Forest Products Laboratory, Madison, WI, revised April 1975.

Caring For Your Home: A Guide to Maintaining Your Investment, National Association of Home Builders Home Builder Press, Washington, DC, 1998.

Your New Home and How to Take Care of It, National Association of Home Builders Home Builder Press, Washington, DC, 2001.

A Builder's Guide to Marketable, Affordable, Durable, Entry-Level Homes to Last, U.S. Department of Housing and Urban Development, Washington, DC, 1999.

Residential Construction Performance Guidelines, National Association of Home Builders, Washington, DC, 2000.

Foundation/Site (Chapter 3)

Design Guide for Frost-Protected Shallow Foundations, Sponsored by the U.S. Department of Housing and Urban Development and the U.S. Department of Energy, NAHB Research Center, Inc., Upper Marlboro, MD, 1996.

Flashing (Chapter 4)

McDaniel, P., iWrapping the House: Doís & Doníts,î *Journal of Light Construction*, March 2000.

Preventing Damage from Ice Dams, Technical Bulletin (Form No. 215-RR-87), Asphalt Roofing Manufacturers Association, Calverton, MD, March 1993.

McCampbell, H., iTroubleshooting Roof Leaks,î *Journal of Light Construction*, October, 1999.

Larson, J. R., iHow to Avoid Common Flashing Errors,î *Fine Homebuilding*, April/May 1998.

Arnold, R. and M. Guertin, iInstalling Vinyl-Clad Windows,î *Fine Homebuilding*, February/ March 2000.

Carrier, J., iKeeping Water Out of Brick Veneer,î *Journal of Light Construction*, November 1999.

SMACNA, *Architectural Sheet Metal Manual*, 5th Edition, Sheet Metal and Air Conditioning Contractors National Association, 1993.

Housewrap (Chapter 4)

Bosack, E. J. and E. F. P. Burnett, *The Use of Housewrap in Walls: Installation, Performance and Implications*, PHRC Report No. 59, The Pennsylvania Housing Research Center, University Park, PA, December 1998.

Light Frame House Construction, Technical Information for the use of Apprentice and Journeyman Carpenters, Vocational Division Bulletin No.145, U.S. Department of Health, Education, and Welfare, Washington, DC, 1931 (reprinted 1956).

Ventilation Issues (Chapter 4)

Cushman, T., iRoof Venting: How Much Is Enough?,[†] *Journal of Light Construction*, December 1996.

TenWolde, A. and W. B. Rose, iIssues related to venting of attics and cathedral ceilings,[†] *ASHRAE Transactions*, V. 105, Pt. 1, American Society of Heating, Refrigerating and Air-Conditioning Engineers, Inc., Atlanta, GA, 1999.

Fugler, D. W., iConclusions from ten years of Canadian attic research,[†] *ASHRAE Transactions*, V. 105, Pt. 1, American Society of Heating, Refrigerating and Air-Conditioning Engineers, Inc., Atlanta, GA, 1999.

Recommended Practices for Controlling Moisture in Crawl Spaces, ASHRAE Technical Data Bulletin, Volume 1Q, Number 3, American Society of Heating, Refrigerating and Air-Conditioning Engineers, Inc., Atlanta, GA, 1999.

Rose, W. B. and A. TenWolde, iMoisture Control in Crawl Spaces,[†] *Wood Design Focus*, Forest Products Society, Madison, WI, Winter 1994.

Rose, W. B., iHeat and moisture performance in attics and cathedral ceilings,[†] *Wood Design Focus*, Forest Products Society, Madison, WI, Winter 1994.

Best, Don, iCrawlspace ventilation update,[†] *Journal of Light Construction*, August 1999.

Insects (Chapter 6)

Wood Handbook ñ Wood as an Engineered Material, U.S. Department of Agriculture, Forest Products Laboratory, Madison, WI, 1999.

Design of Wood Frame Structures for Permanence, National Forest Products Association, Washington, DC, 1988.

Manual of Acceptable Practices, Vol. 4, U.S. Department of Housing and Urban Development, 1973.

Hu, X.P., D. Ring, A. Morgan, D. Pollet, *A Guide for Integrated Pest Management of Termites*, AgCenter, Louisiana State University, LA., 2000.

Mankowski, M. and J.J. Morrell, iIncidence of Wood-destroying organisms in Oregon residential structures,[†] *Forest Products Journal*, Vol. 50, No. 1, Forest Products Society, Madison, WI, January 2000.

Kard, B., iTermite Control: Results of Testing at the U.S. Forest Service,[†] National Pest Control Association, Dunn Loring, VA, October 1998.

Kard, B., iTermiticides ñ The Gulfport Report,[†] *Pest Control*, Advanstar Publications, U.S.A., February 1999.

Approved Reference Procedures for Subterranean Termite Control, National Pest Control Association, Dunn Loring, VA, 1991.

Decay & Corrosion (Chapter 7)

see General plus:

- McDonald, K.A., R.H. Faulk, R.S. Williams, J.E. Winandy, *Wood Decks: Materials, Construction, and Finishing*, Forest Products Society, Madison, WI, 1996.
- Micklewright, James T., *Wood Preservation Statistics 1997*, prepared for the American Wood-Preservers' Association, Granbury, TX, 1998.
- Smulski, Stephen, *Preservative-treated wood, lumber that can last a lifetime*, *Fine Homebuilding*, No. 63, October/November 1990, pp.61-65.
- Baker, A.J., *Corrosion of nails in CCA- and ACA-treated wood in two environments*, *Forest Products Journal*, Vol. 42, No. 9, September 1992.

Natural Disasters (Chapter 8)

- Assessment of Damage to Single-Family Homes Caused by Hurricanes Andrew and Iniki*, U.S. Department of Housing and Urban Development, Washington, DC, 1993.
- Assessment of Damage to Homes Caused by Hurricane Opal*, prepared for the Florida State Home Builders Association by the NAHB Research Center, Inc., Upper Marlboro, MD, 1996.
- Assessment of Damage to Residential Buildings Caused by the Northridge Earthquake*, U.S. Department of Housing and Urban Development, Washington, DC, 1994.
- Sciaudone, J., *Non-Structural Seismic Retrofits Can Make a Bit Difference*, *Building Standards*, Vol. LXIX, No. 6, International Conference of Building Officials, Whittier, CA, November-December 2000.

Glossary

- Air barrier (also known as air retarder) ñ** material(s) used in design to reduce the flow of air between indoors and outside. Air barriers may also serve as drainage planes in some cases.
- Building code ñ** a set of building construction requirements developed by national bodies which are adopted and administered by local institutions to certify that buildings (residential buildings in this case) meet certain minimum standards for structural integrity, safety, and durability.
- Carpet soiling ñ** the discoloration of carpets in houses due to a combination of conditions that usually includes airflow under doors or wall baseplates and a source of dirt, soot, or airborne particulates.
- Damproofing, foundation ñ** treatment of concrete or mortar to retard the passage or absorption of water, or water vapor, usually by applying a suitable coating to exposed surfaces.
- Drainage plane ñ** the part(s) of a building's weather barrier system that exhibits a high degree of resistance to liquid water from outdoors, usually in the form of a water resistant membrane, layer, or sheet; used in combination with appropriate flashing and sealing details at discontinuities in the wall assembly (e.g., penetrations for windows, doors, etc.) or at the drainage plane material itself (e.g., lap joints between sheets).
- Drying potential ñ** the ability or capacity of a material or combinations of materials to dry once wetted; in residential wall systems this ability is strongly influenced by the presence or absence of a vapor retarder(s) and the driving forces for drying (vapor pressures, temperature).
- Durability ñ** the ability of a material, product, or building to maintain its intended function for its intended life-expectancy with intended levels of maintenance in intended conditions of use.
- Perm rating (vapor permeance) ñ** a measure, for a given thickness, of a material's ability to transmit water vapor (1 perm = 1 gr/h* ft²*in.Hg); a high perm rating indicates that a material can readily allow water vapor to pass through it (e.g., gypsum), a low perm rating

indicates that a material will not allow water vapor to pass (e.g., plastic sheeting)

- Sones ñ** a unit of sound measurement used in HVAC applications to rate fan noise; standard bathroom exhaust fan have ratings of 4 Sones or more.
- Swale ñ** a stormwater runoff feature formed from natural materials like soil and vegetation that collects and channels water runoff; swales can serve as an alternative to curb and gutter systems, and allow for some water infiltration back into the ground instead.
- Termite barrier ñ** any building material or component which is impenetrable to termites and which drives the insect into the open where its activities can be detected.
- Ultraviolet (UV) radiation ñ** a form of energy from the sun in a non-visible wavelength that can cause chemical reactions in exposed materials and subsequent fatigue and discoloration.
- Vapor retarder (also known as vapor barrier) ñ** a layer in a building construction (wall, floor, or roof/ceiling) that restricts the diffusion of water vapor. The diffusion of water vapor can be driven by differences in vapor pressure. Water vapor will be driven from a location of high vapor pressure (i.e., high humidity) to low vapor pressure (i.e., low humidity). Typically, in cold climates the indoor air is at a higher vapor pressure than the outdoor air that is dryer and colder. The opposite is true in hot/humid climates where the lower vapor pressure is indoors (and is accentuated by use of air-conditioners and associated dehumidification). Vapor retarders have a perm rating of 1 or less.
- Waterproofing (foundation) ñ** a procedure to make a material impervious to water or dampness. The application of a material or coating to assure water repellency to a structure or construction unit.
- Water vapor diffusion ñ** the movement of water vapor (gaseous water) driven by vapor pressure differentials.
- Weather barrier ñ** general term for a combination of materials including siding, roofing, flashing, sheathing, finishes, drainage plane, and vapor retarders that, as a system, exhibit vapor retarding and water retarding characteristics and may also possess thermal insulation and air infiltration characteristics.

APPENDIX A - Durability Checklists

Designer's & Builder's Durability Checklist

- ÿ Have adequate roof overhangs been specified?
- ÿ Does the roof have adequate slope for the roofing material being used?
- ÿ Has valley flashing been adequately detailed?
- ÿ Has shading of the building been considered and planned?
- ÿ Have all roofing penetrations been adequately flashed and detailed?
- ÿ Have gutters been sized and specified?
- ÿ Has downspout size, location, and outlet point been detailed?
- ÿ Has roof drip edge been specified?
- ÿ Has eave ice flashing been specified, if required?
- ÿ Has 15# roofing felt been specified?
- ÿ Has attic vent location and design been specified?
- ÿ Has a secondary drainage plane been specified where required (building wrap, 15# felt, etc.)?
- ÿ Are the drainage plane and flashings at windows and doors properly detailed?
- ÿ Have window head, jamb, and sill flashing details been specified?
- ÿ Have door head flashing details been specified?
- ÿ Has siding corner detail been specified?
- ÿ Has air barrier detailing been specified, if needed?
- ÿ Has siding selection been specified?
- ÿ Have all railing details been specified?
- ÿ Has the location and flashing for utility penetrations been specified?
- ÿ Have all bathroom, dryer, and kitchen vents been specified to be directly vented to the exterior of the building?
- ÿ Does site have adequate slope to remove roof run-off?
- ÿ Has adequate foundation backfill material been specified?
- ÿ Are ground clearances between framing, siding, and ground properly maintained?
- ÿ Is treated lumber used where clearances to ground are not sufficient?
- ÿ Is foundation drain specified with proper aggregate and filter fabric?
- ÿ Are drainpipes located below the top surface of the basement slab?
- ÿ Is the foundation drainage system properly installed to provide positive flow of foundation water away from the building?
- ÿ Is foundation drain outlet specified - either through daylighting or sump pump?
- ÿ Are foundation bleed holes specified, if needed?
- ÿ Is foundation wall damp proofing or waterproofing specified as required?
- ÿ Are termite protection measures specified?
- ÿ Is basement floor gravel layer specified?
- ÿ Has crawlspace, slab, or basement floor vapor barrier been specified?

Homeowner's Durability Checklist

- ÿ Inspect/replace caulk every 2-3 years.
- ÿ Maintain gutters and downspouts in a clean and operating condition.
- ÿ Adjust landscaping sprinklers such that the house is not accidentally iwatered regularly.
- ÿ Repaint every 5-7 years.
- ÿ Maintain exterior grade near foundation for drainage away from the house.
- ÿ Maintain indoor relative humidity levels below 60% through the use of the HVAC equipment (heating during winter, cooling during summer) and auxiliary dehumidifiers in damp areas like basements.
- ÿ Inspect/replace HVAC filter monthly and have an annual service check on equipment.
- ÿ Use exhaust fans whenever showering or generating significant moisture while cooking.
- ÿ Do not exhaust clothes dryer to indoors or enclosed spaces.
- ÿ Use unvented combustion appliances only in accordance with manufacturers recommendations.
- ÿ Address all leaks and floods promptly, however small they may seem.
- ÿ Inspect/replace washer hoses periodically.

APPENDIX B - Estimated Life- Expectancy of Building Materials and Products

ESTIMATED LIFE EXPECTANCY AND HOMEOWNER MAINTENANCE CHART

Building Component	Estimated Life* (years)	Homeowner Action
Concrete/block foundation	100+	Check for cracks or surface deterioration. Consult a professional if you have any leaking or severe cracking. Check for termite tubes on foundation.
Exposed concrete slabs	25	Inspect for cracking. Seal to prevent water penetration.
Siding (Lifespan depends on type)	10 - 100	Clean all types of siding. Paint or seal wood siding (See exterior paints/stains).
Drywall	30 - 70	Inspect, clean, and paint for aesthetic purposes.
Roofing	15 - 30	Inspect for missing or deteriorated shingles. Clean to remove mold buildup.**
Gutters and Downspouts	30	Remove debris.
Insulation	100+	Inspect blown insulation in attic and check floor insulation (crawlspcace) to assure that it is in place.
Windows	20 - 50	Inspect and repair weather stripping. Inspect for broken seals in insulated windows. Clean exterior window frames.**
Exterior Doors	25 - 50	Clean and refinish when necessary (See Exterior paints/stains).
Garage Doors	20 - 50	Clean garage door. Lubricate moving parts. Paint or seal as necessary.**
Exterior paints/stains	7 - 10	Clean and inspect. Repaint and caulk as needed.
Wood floors	100+	Clean and wax.
Carpeting	11	Clean annually.

*All numbers excerpted and condensed from: NAHB Life Expectancy Survey from iHousing, Facts, Figures and Trends! (1997)

**Use care if power washing. The high pressure water can cause more harm than help if not used cautiously.

ESTIMATED LIFE EXPECTANCY AND HOMEOWNER MAINTENANCE CHART (CONTINUED)		
<u>Building Component</u>	<u>Estimated Life* (years)</u>	<u>Homeowner Action</u>
Sinks	5 - 30	Keep free of debris.
Toilets	50	Keep free of debris. Check tank seal and floor wax collar for leaks.
Faucets	13 - 20	Clean screen annually. Check for leaking seals.
Water heater	14	Keep clear of household items. Have professional maintenance annually.
Central air conditioning/ heat pump (outside unit)	15	Keep free of plants and debris. Cover during winter months (A/C only). Conduct annual professional maintenance.
Furnace/heat pump (indoor unit)	18	Keep clear of household items. Conduct annual professional maintenance. Inspect/replace filter according to manufacturer's recommendations.
Refrigerator	17	Clean condensing coils regularly; allow room behind and inside appliance for air circulation.
Dishwasher	10	Clean the drain filter regularly.
Clothes Dryer	14	Clean lint filter regularly. Periodic professional cleanings will reduce risk of fire.
Clothes Washer	13	Keep lint trap free of debris. Clean tank occasionally.
Smoke Detector	12	Test and check batteries.
Wood Framing	100+	(See termite protection.)
Termite protection (chemical treatment)	5	Yearly inspection and retreat as necessary.

*All numbers excerpted and condensed from: NAHB Life Expectancy Survey from iHousing, Facts, Figures and Trends (1997)

**Use care if power washing. The high pressure water can cause more harm than help if not used cautiously.

